

TECHNICAL SHEET

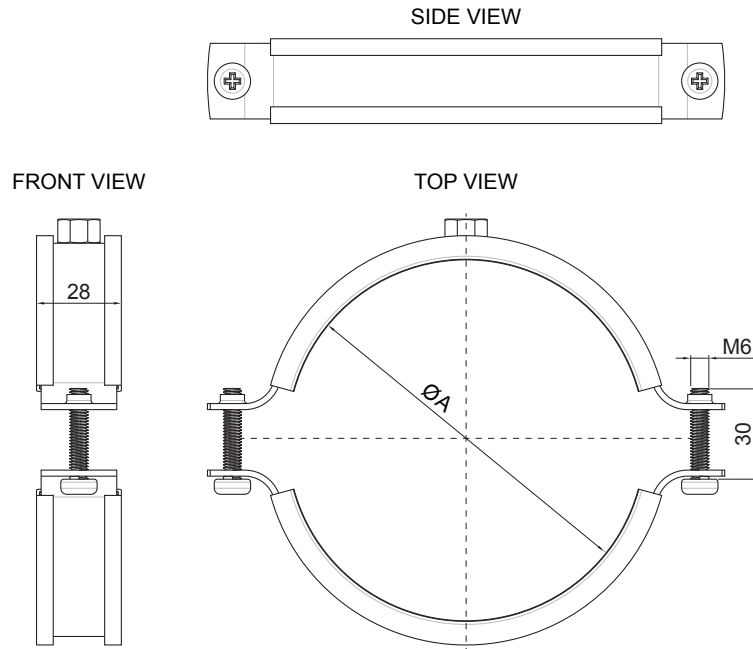

DOWNPIPE BRACKET WITH GASKET M 10

P-POB-OZR



P Galvanized steel – Natur

Dimensions [mm]	
Nominal size	Ø A
80	78
100	98
120	120

INDEX	CHANGE	DATE	SIGNATURE	 	
MATERIAL BRAND			W.C.	WEIGHT kg	SCALE
SIZE, SEMI-FINISHED PRODUCTS				STN STANDARD	SORTING NUMBER
AUXILIARY EQUIPMENT				NOTE	POSITION NUMBER
ELABORATED BY Ing. Kluska M.					
TESTED BY					
TECHNOLOGIST		TECHNOLOGIST		OLD DRAWING	DRAWING NUMBER
NAME Downpipe bracket with gasket M 10				Number of sheets	P-POB-OZR Sheet 

Created: 03.06.2026 23:36:21

Technical changes reserved