

TECHNICAL SHEET

DOWNPIPE BRACKET WITH THREAD M 10

N-NOB

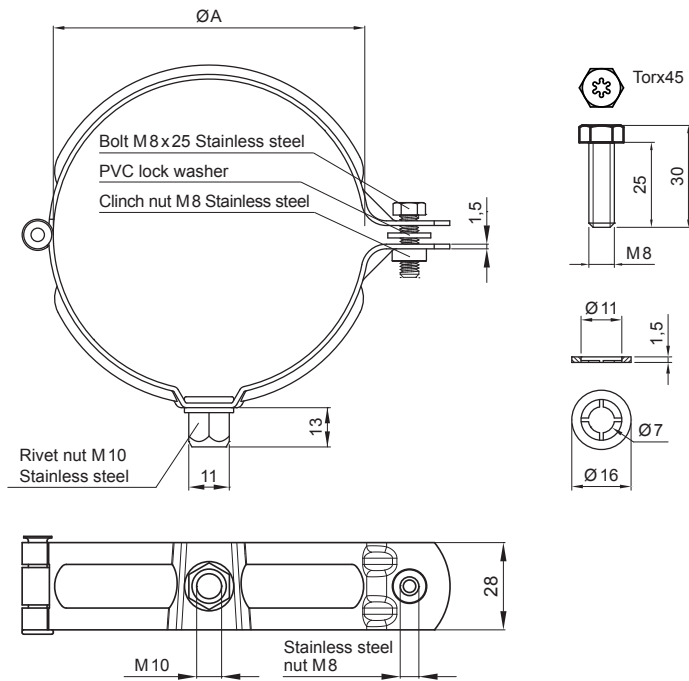

304 2B Stainless steel – AISI 304 2B – MATT

Dimensions [mm]			
Nominal size	$\varnothing A$	B	
60	60	13	
80	80	13	
100	100	13	
120	120	13	

INDEX	CHANGE	DATE	SIGNATURE	KJG QUALITY®	Scan code for 3D model
MATERIAL BRAND			W.C.	WEIGHT kg	SCALE
SIZE, SEMI-FINISHED PRODUCTS					
AUXILIARY EQUIPMENT			STN STANDARD		SORTING NUMBER
ELABORATED BY Ing. Kluska M.			NOTE		POSITION NUMBER
TESTED BY					
TECHNOLOGIST		TECHNOLOGIST	OLD DRAWING		DRAWING NUMBER
NAME Downpipe bracket with thread M 10			Number of sheets		N-NOB Sheet

Created: 06.06.2026 16:05:09

Technical changes reserved