

TECHNICAL SHEET

HOOK FASCIA

W-WHPK

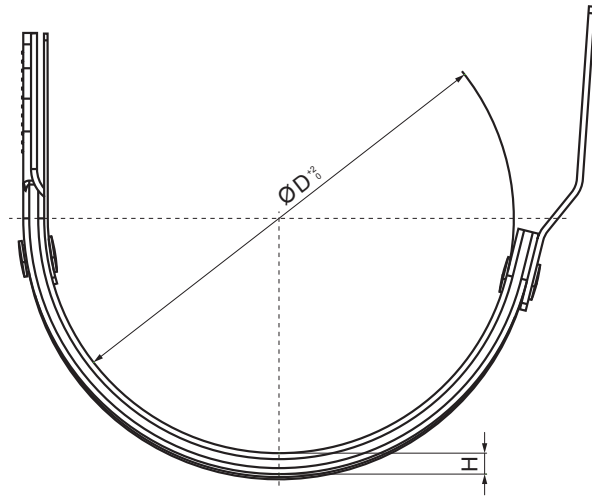
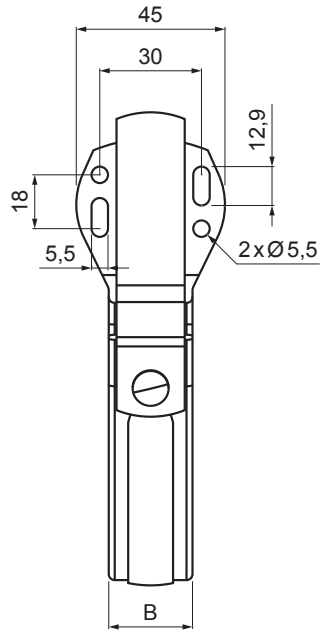

AN Aluminium pre-painted – Anthracite – RAL 7016

Dimensions [mm]		
Nominal size	B x H	Ø D
250	28 x 7	105
280	28 x 7	127
333	28 x 7	153
400	28 x 7	192

INDEX	CHANGE	DATE	SIGNATURE	KJG QUALITY®	Scan code for 3D model
MATERIAL BRAND			W.C.	WEIGHT kg	SCALE
SIZE, SEMI-FINISHED PRODUCTS				STN STANDARD	SORTING NUMBER
AUXILIARY EQUIPMENT				NOTE	POSITION NUMBER
ELABORATED BY Ing. Kluska M.					
TESTED BY				OLD DRAWING	DRAWING NUMBER
TECHNOLOGIST			TECHNOLOGIST		
NAME			Hook fascia		
			Number of sheets	W-WHPK	Sheet

Created: 21.04.2026 18:16:38

Technical changes reserved