

TECHNICAL SHEET

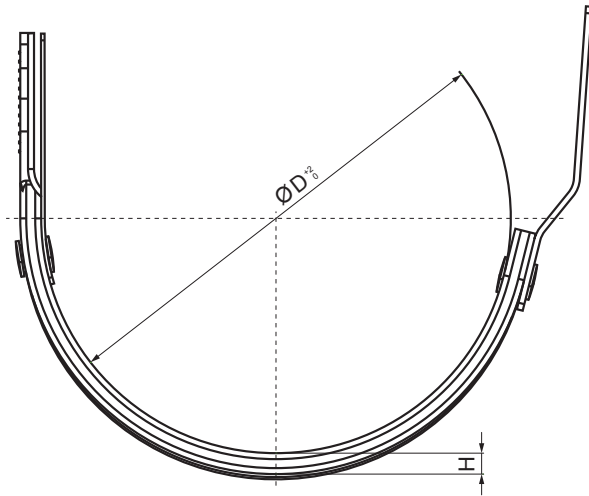

HOOK FASCIA

W-WHPK

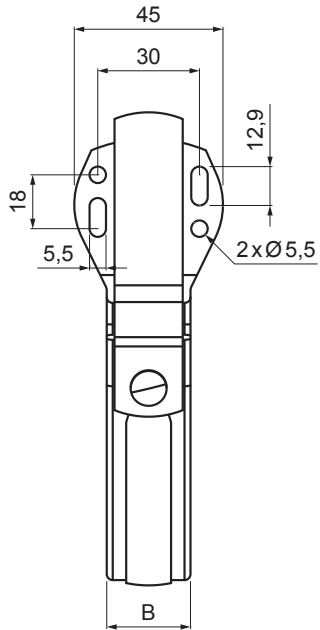

TM Aluminium pre-painted – Testa di Moro – RAL 8028

Dimensions [mm]		
Nominal size	B x H	Ø D
250	28 x 7	105
280	28 x 7	127
333	28 x 7	153
400	28 x 7	192

INDEX	CHANGE	DATE	SIGNATURE		
MATERIAL BRAND			W.C.	WEIGHT kg	SCALE
SIZE, SEMI-FINISHED PRODUCTS				STN STANDARD	SORTING NUMBER
AUXILIARY EQUIPMENT				NOTE	POSITION NUMBER
ELABORATED BY Ing. Kluska M.					
TESTED BY				OLD DRAWING	DRAWING NUMBER
TECHNOLOGIST			TECHNOLOGIST		
NAME			Hook fascia		
			Number of sheets	W-WHPK	Sheet 

Created: 04.06.2026 06:17:05

Technical changes reserved