

# TECHNICAL SHEET

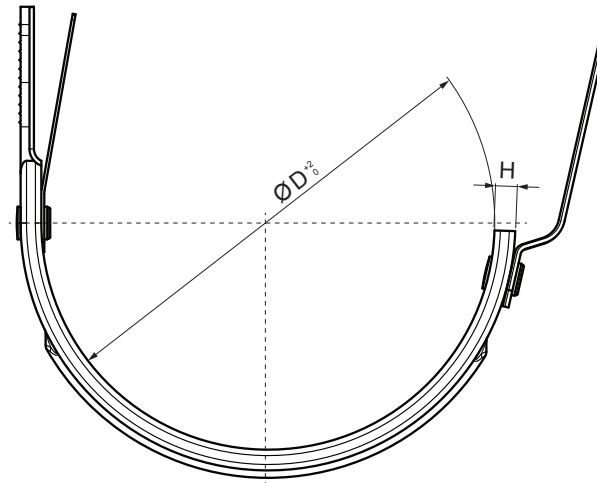

## HOOK FASCIA

# W-WHPK

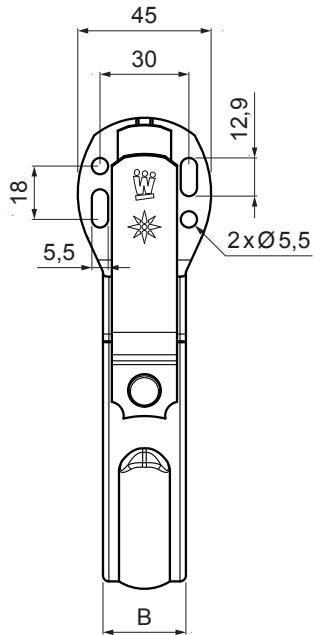

**W** Aluminium – Natur

Dimensions [mm]		
Nominal size	B x H	Ø D
250	28 x 7	105
280	28 x 7	127
333	28 x 7	153
400	28 x 7	192

INDEX	CHANGE	DATE	SIGNATURE		
MATERIAL BRAND			W.C.	WEIGHT kg	SCALE
SIZE, SEMI-FINISHED PRODUCTS				STN STANDARD	SORTING NUMBER
AUXILIARY EQUIPMENT				NOTE	POSITION NUMBER
ELABORATED BY Ing. Kluska M.				OLD DRAWING	DRAWING NUMBER
TESTED BY					
TECHNOLOGIST		TECHNOLOGIST		Number of sheets	W-WHPK Sheet
NAME			Hook fascia		

Created: 04.06.2026 02:59:04

Technical changes reserved