

TECHNICAL SHEET HOPPER DESIGN

W-WKLZ DE

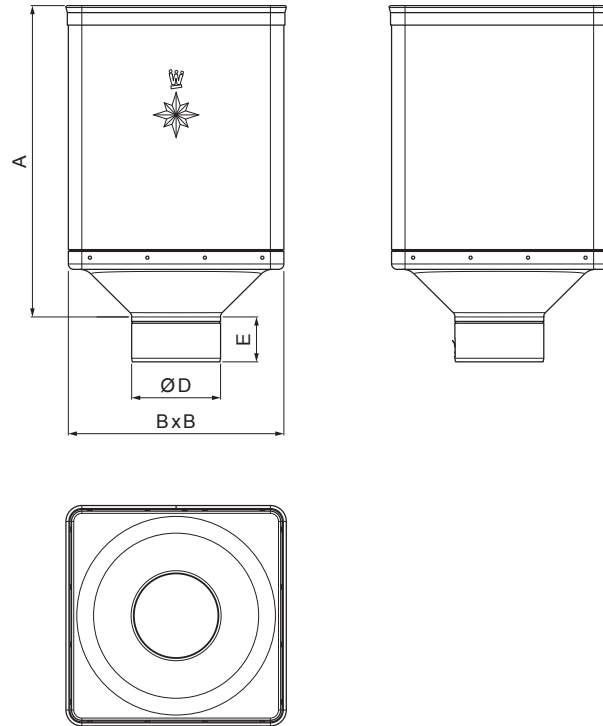

OC Aluminium pre-painted – Steel red – RAL 3009

INDEX	CHANGE	DATE	SIGNATURE	KJG QUALITY®	Scan code for 3D model
MATERIAL BRAND			W.C.	WEIGHT kg	SCALE
SIZE, SEMI-FINISHED PRODUCTS				STN STANDARD	SORTING NUMBER
AUXILIARY EQUIPMENT				NOTE	POSITION NUMBER
ELABORATED BY Ing. Kluska M.					
TESTED BY					
TECHNOLOGIST		TECHNOLOGIST		OLD DRAWING	DRAWING NUMBER
NAME Hopper DESIGN				Number of sheets	W-WKLZ DE Sheet

Created: 21.04.2026 04:40:00

Technical changes reserved

Dimensions [mm]				
Nominal size	A	B	D	E
80	340	240	79	44
100	336	240	99	50
120	333	240	119	60