

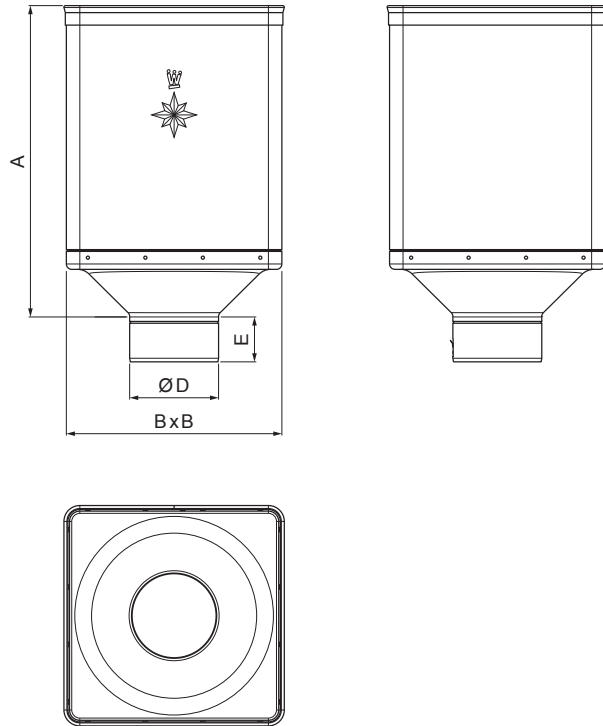

TECHNICAL SHEET HOPPER DESIGN

W-WKLZ DE



ZS Aluminium pre-painted – Zinc grey – RAL extra

| | | | | | |
|------------------------------|--------|--------------|-----------|------------------------|--|
| INDEX | CHANGE | DATE | SIGNATURE | KJG QUALITY® | Scan code for 3D model  |
| | | | | | |
| MATERIAL BRAND | | | W.C. | WEIGHT kg | SCALE |
| SIZE, SEMI-FINISHED PRODUCTS | | | | STN STANDARD | SORTING NUMBER |
| AUXILIARY EQUIPMENT | | | | NOTE | POSITION NUMBER |
| ELABORATED BY Ing. Kluska M. | | | | | |
| TESTED BY | | | | | |
| TECHNOLOGIST | | TECHNOLOGIST | | OLD DRAWING | DRAWING NUMBER |
| NAME Hopper DESIGN | | | | Number of sheets | W-WKLZ DE Sheet  |

Created: 04.06.2026 06:17:03

Technical changes reserved

| Dimensions [mm] | | | | |
|-----------------|-----|-----|-----|----|
| Nominal size | A | B | D | E |
| 80 | 340 | 240 | 79 | 44 |
| 100 | 336 | 240 | 99 | 50 |
| 120 | 333 | 240 | 119 | 60 |