

TECHNICAL SHEET

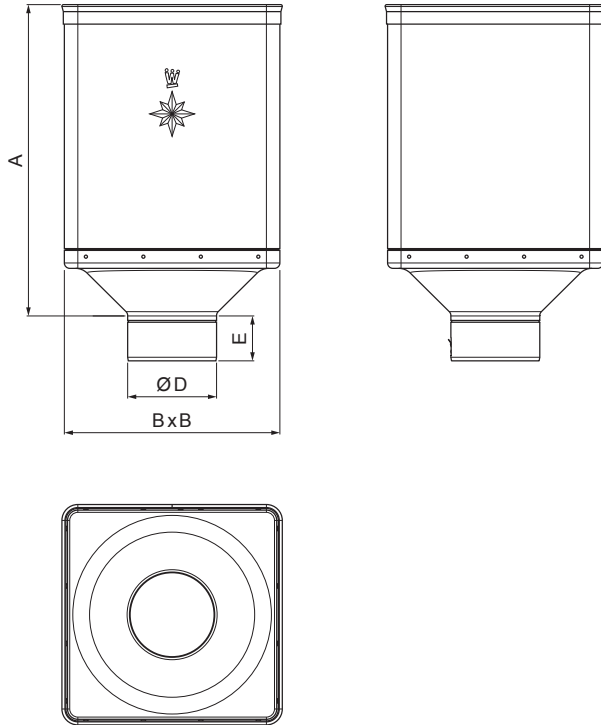

HOPPER DESIGN

W-WKLZ DE



W Aluminium – Natur

Dimensions [mm]				
Nominal size	A	B	D	E
80	340	240	79	44
100	336	240	99	50
120	333	240	119	60

INDEX	CHANGE	DATE	SIGNATURE	 	
MATERIAL BRAND			W.C.	WEIGHT kg	SCALE
SIZE, SEMI-FINISHED PRODUCTS				STN STANDARD	SORTING NUMBER
AUXILIARY EQUIPMENT				NOTE	POSITION NUMBER
ELABORATED BY Ing. Kluska M.					
TESTED BY					
TECHNOLOGIST		TECHNOLOGIST		OLD DRAWING	DRAWING NUMBER
NAME			Hopper DESIGN Number of sheets W-WKLZ DE Sheet		

Created: 05.06.2026 08:23:46

Technical changes reserved