

TECHNICAL SHEET

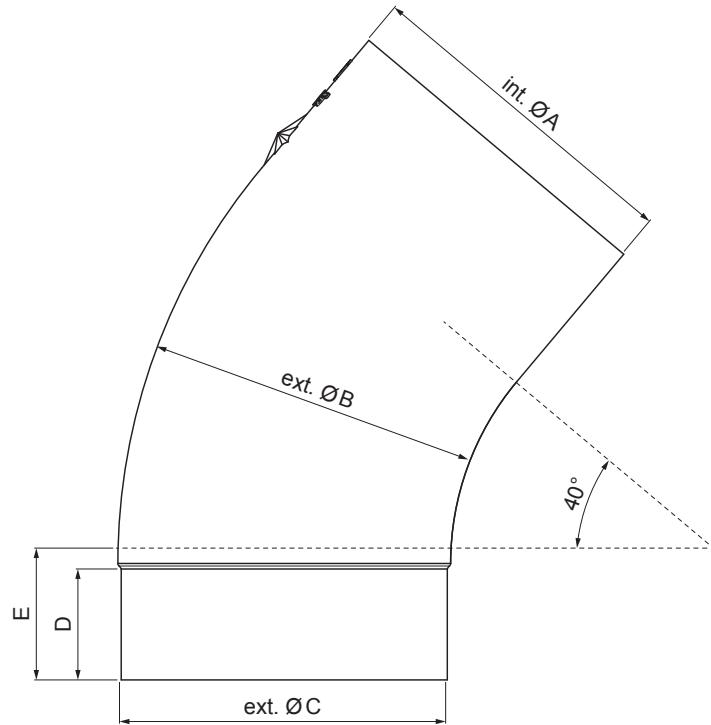

ELBOW BLIND 40°

W-WKT



W Aluminium – Natur

Dimensions [mm]					
Nominal size	$\varnothing A$	$\varnothing B$	$\varnothing C$	D	E
80	80,4	79	76,9	28	40
100	100,4	99,0	96,8	35	50
120	120,3	119,0	116,7	42	60

INDEX	CHANGE	DATE	SIGNATURE		
MATERIAL BRAND			W.C.	WEIGHT kg	SCALE
SIZE, SEMI-FINISHED PRODUCTS				STN STANDARD	SORTING NUMBER
AUXILIARY EQUIPMENT				NOTE	POSITION NUMBER
ELABORATED BY Ing. Kluska M.				OLD DRAWING	DRAWING NUMBER
TESTED BY					
TECHNOLOGIST			TECHNOLOGIST		
NAME			Elbow blind 40°		
			Number of sheets	W-WKT	Sheet 

Created: 05.06.2026 10:52:40

Technical changes reserved