

TECHNICKÝ LIST

# ŽLABOVÝ KOTLÍK

# W.15-WKL

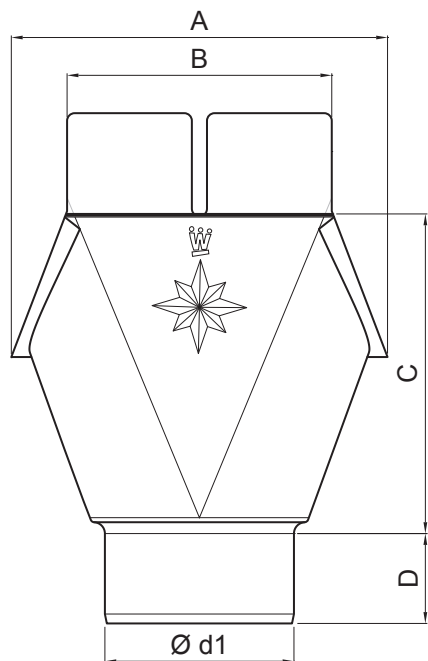

**BHM** Hliník lakovaný W.15 – Bielo hliníková W.15 – RAL 9006

Rozmery [mm]							
Menovitá veľkosť	Ø d1	Ø d2	A	B	C	D	E
250/80	80	105	140	120	117,5	40	12
280/80	80	127	165	120	143,5	40	12
280/100	100	127	165	120	142,5	45	14
333/80	80	153	185	140	176,5	40	14
333/100	100	153	185	140	170,0	45	14
333/120	120	153	185	140	171,50	50	14
400/120	120	192	210	160	200,4	51	14
400/150	150	192	240	168	205,0	45	14

INDEX	ZMENA	DATUM	PODPIS	<b>KJG</b> QUALITY®	Scan code for 3D model	
ZN. MAT.						
ROZM.-POLOT						
POM. ZAR.					STN	TR.Č.
VYPR. Ing. Kluska M.					POZN.	Č.POZÍCIE
PRESK.						
TECHNOL.	TECHNOL.				STARÝ V.	Č.V.
NÁZOV	Žľabový kotlík				Počet listov	W.15-WKL
						List

Vytvorené: 21.04.2026 14:23:24

Technické zmeny vyhradené