

TECHNICKÝ LIST

STREŠNÝ ŽLAB HRANATÝ [s=0,55]

PH-PZH D

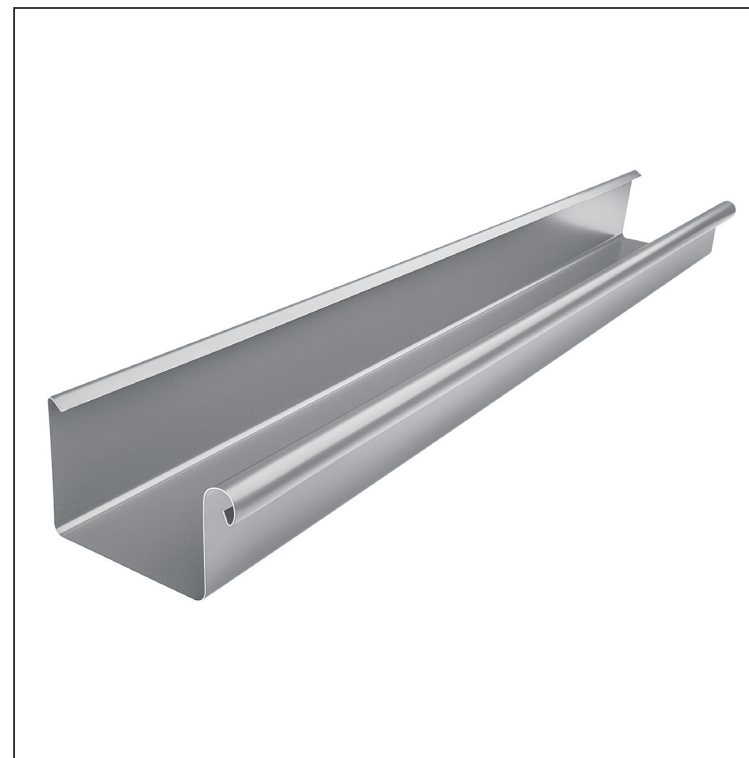

PS Pozink lakovaný – Prachovo šedá – RAL 7037

Rozmery [mm]							
Menovitá veľkosť	S	A	B	C	ØD	E	F min.
200	0,55	42	70	5	16	5	8
250	0,55	55	85	7	18	5	10
333	0,55	75	120	7	20	6	11
400	0,55	90	150	9	22	6	11
500	0,55	110	200	9	22	6	11

INDEX	ZMENA	DATUM	PODPIS	KJG QUALITY®	Scan code for 3D model		
ZN. MAT.							T.O.
ROZM.-POLOT							
POM. ZAR.					STN	TR.Č.	
VYPR. Ing. Kluska M.					POZN.	Č.POZÍCIE	
PRESK.							
TECHNOL.	TECHNOL.				STARÝ V.	Č.V.	
NÁZOV	Strešný žlab hranatý [s=0,55]				Počet listov	PH-PZH D	List

Vytvorené: 21.04.2026 20:06:34

Technické zmeny vyhradené