

TECHNICKÝ LIST

STREŠNÝ ŽĽAB HRANATÝ [s=0,70]

WH-WZHD

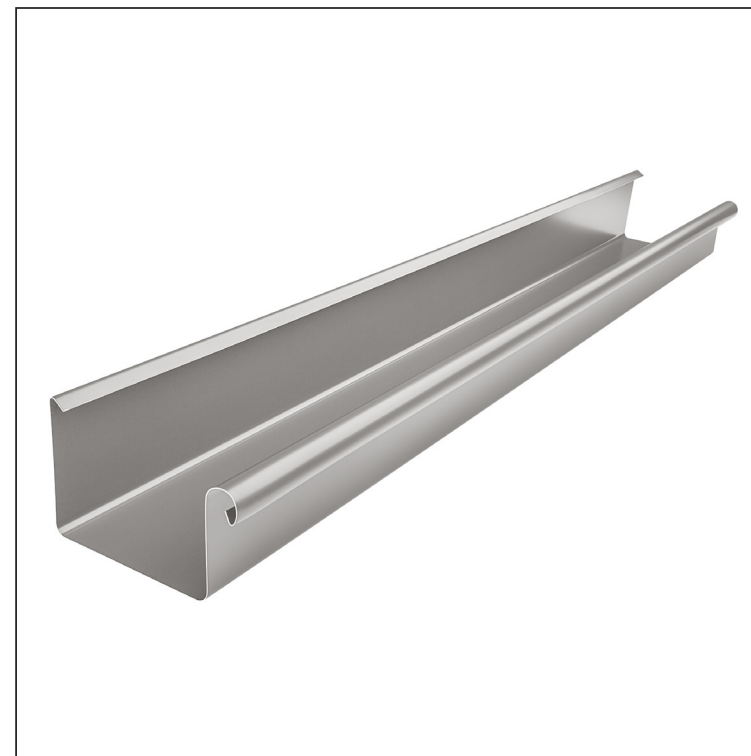

BHT Hliník lakovaný – Bielo hliníková tmavá – RAL 9007

Rozmery [mm]							
Menovitá veľkosť	S	A	B	C	ØD	E	F min.
250	0,70	55	85	7	18	5	10
333	0,70	75	120	7	20	6	11
400	0,70	90	150	9	22	6	11

INDEX	ZMENA	DATUM	PODPIS	KJG QUALITY®	Scan code for 3D model		
ZN. MAT.							T.O.
ROZM.-POLOT							
POM. ZAR.					STN	TR.Č.	
VYPR.	Ing. Kluska M.				POZN.	Č.POZÍCIE	
PRESK.							
TECHNOL.	TECHNOL.				STARÝ V.	Č.V.	
NÁZOV	Strešný žľab hranatý [s=0,70]				Počet listov	WH-WZHD	List

Vytvorené: 06.06.2026 08:22:26

Technické zmeny vyhradené