

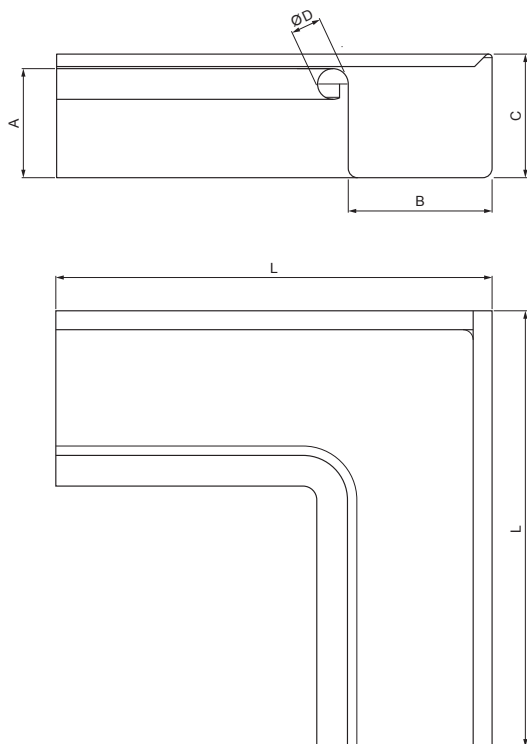

TECHNICKÝ LIST

# ŽLABOVÝ ROH VNÚTORNÝ HRANATÝ

## W.15H-WRIH



**BHM** Hliník lakovaný W.15 – Bielo hliníková W.15 – RAL 9006

INDEX	ZMENA	DATUM	PODPIS	<b>KJG</b> QUALITY®	Scan code for 3D model 	
ZN. MAT.						T.O.
ROZM.-POLOT					STN	TR.Č.
POM. ZAR.					POZN.	Č.POZÍCIE
VYPR. Ing. Kluska M.					STARÝ V.	Č.V.
PRESK.						
TECHNOL.	TECHNOL.					
NÁZOV	Žľabový roh vnútorný hranatý			Počet listov	W.15H-WRIH	List 

Vytvorené: 07.06.2026 13:05:30

Technické zmeny vyhradené

Rozmery [mm]					
Menovitá veľkosť	A	B	C	ØD	L
250	55	85	65	18	285
333	75	120	85	20	275





TECHNICKÝ LIST

# ŽLABOVÝ ROH VNÚTORNÝ HRANATÝ

## W.15H-WRIH



**BHM** Hliník lakovaný W.15 – Bielo hliníková W.15 – RAL 9006

INDEX	ZMENA	DATUM	PODPIS			
ZN. MAT.			T.O.			
ROZM.-POLOT					STN	TR.Č.
POM. ZAR.					POZN.	Č.POZÍCIE
VYPR.	Ing. Kluska M.				STARÝ V.	Č.V.
PRESK.						
TECHNOL.		TECHNOL.				
NÁZOV	Žľabový roh vnútorný hranatý			Počet listov	W.15H-WRIH List 	

Vytvorené: 07.06.2026 13:05:30

Technické zmeny vyhradené

Rozmery [mm]					
Menovitá veľkosť	A	B	C	ØD	L
400	90	150	100	22	400