

TECHNICKÝ LIST

ŽLABOVÝ KOTLÍK

P-PKL

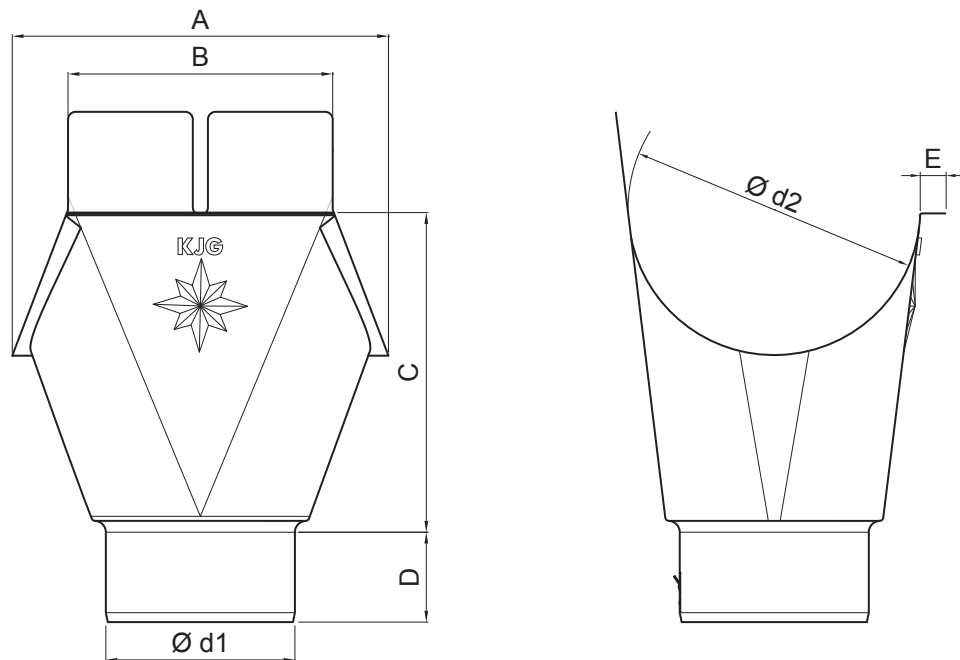

MM Pozink lakovaný – Metalická medená – RAL extra

Rozmery [mm]							
Menovitá veľkosť	Ø d1	Ø d2	A	B	C	D	E
200/60	60	80	115	80	99,5	30	12
250/60	60	105	140	100	127,5	30	12
250/80	80	105	140	120	117,5	40	12
280/80	80	127	165	120	143,5	40	12
280/100	100	127	165	120	142,5	45	14
333/80	80	153	185	140	176,5	40	14
333/100	100	153	185	140	170,0	45	14
333/120	120	153	185	140	171,50	50	14
400/100	100	192	210	160	205,0	45	14
400/120	120	192	210	160	200,4	51	14
400/150	150	192	240	168	205,0	45	14

INDEX	ZMENA	DATUM	PODPIS	KJG QUALITY®	Scan code for 3D model	
ZN. MAT.	ROZM.-POLOT	T.O.	HMOTNOSŤ kg			
POM. ZAR.	VYPR. Ing. Kluska M.	STN	POZN.	TR.Č.	Č.POZÍCIE	
PRESK.	TECHNOL.	STARÝ V.	Č.V.			
NÁZOV	Žľabový kotlík		Počet listov	P-PKL	List	

Vytvorené: 05.06.2026 04:38:18

Technické zmeny vyhradené