

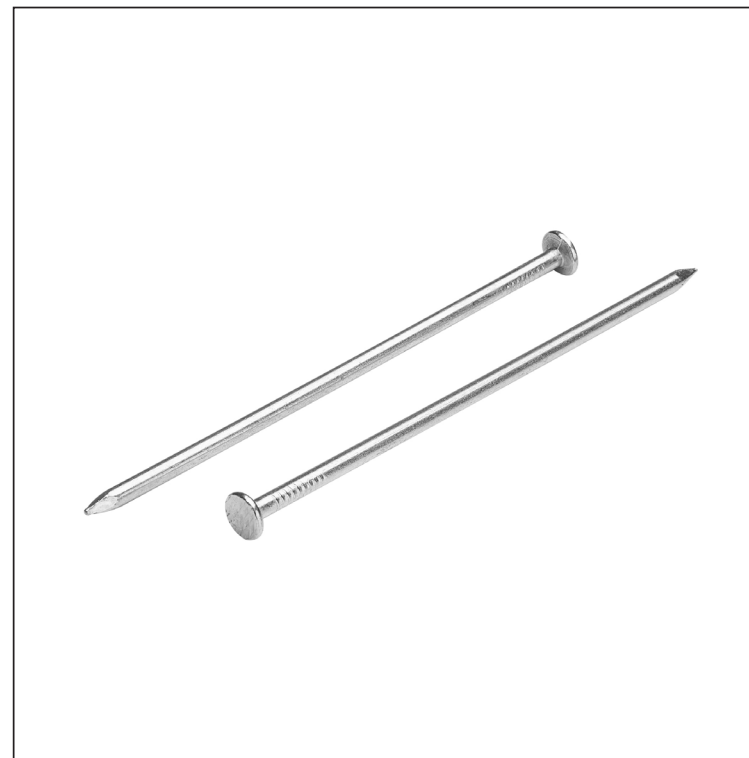

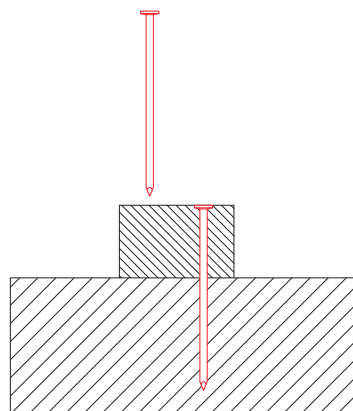

TECHNICKÝ LIST

# OCEĽOVÝ KLINEC STAVEBNÝ S HLAVOU 10 mm SM-OKCSS-H10

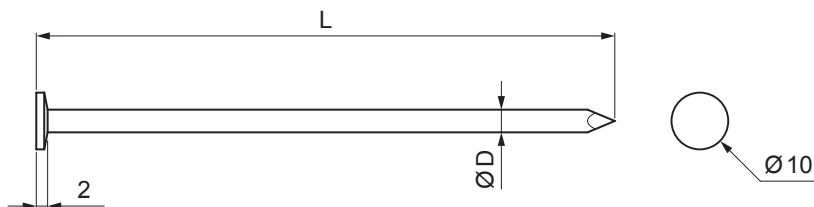

 Oceľ

Rozmery [mm]		
Menovitá veľkosť	Ø D	L
28/63	2,8	63
28/70	2,8	70
31/80	3,1	80
35/90	3,5	90
40/100	4,0	100
40/120	4,0	120
50/150	5,0	150
71/220	7,1	220
88/300	8,8	300

INDEX	ZMENA	DATE	PODPIS	<b>KJG</b> QUALITY®		
ZN. MAT.	ROZM.-POLOT	POM. ZAR.	T.O.			
VYPR. Ing. Kluska M.				STN	TR.Č.	
PRESK.				POZN.	Č.POZÍCIE	
TECHNOL.	TECHNOL.			STARÝ V.	Č.V.	
NÁZOV Oceľový klinec stavebný s hlavou 10 mm				Počet listov	SM-OKCSS-H10	List 

Vytvorené: 21.04.2026 15:50:47

Technické zmeny vyhradené