

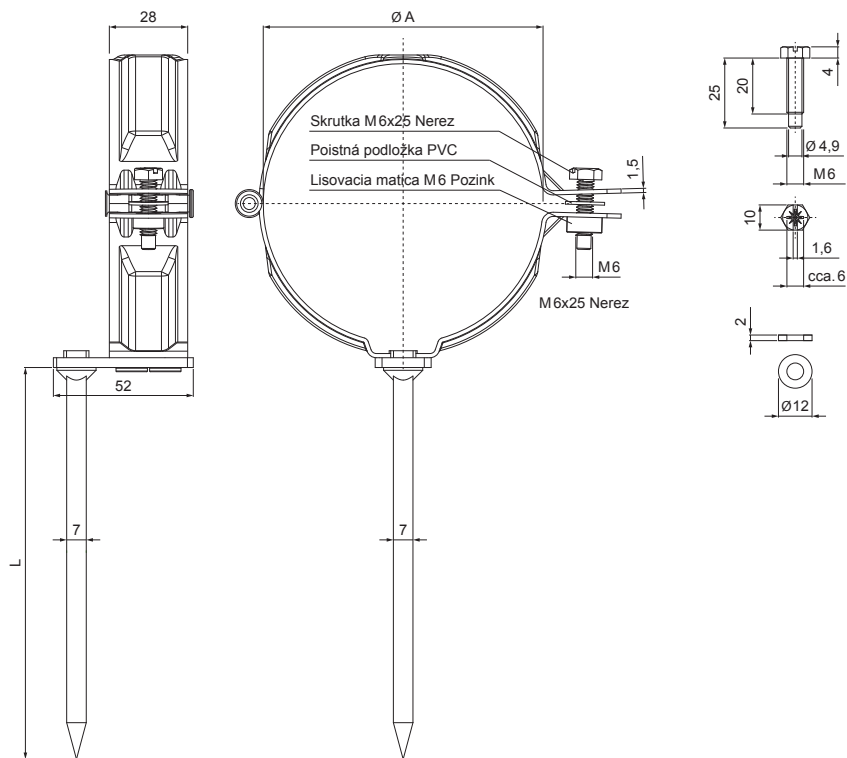

TECHNICKÝ LIST

ZVODOVÁ OBJÍMKA S HROTOM 300 MM

P-PODD



TM Pozink lakovaný – Testa di Moro – RAL 8028

INDEX	ZMENA	DATUM	PODPIS	KJG QUALITY®	Scan code for 3D model 		
ZN. MAT.						T.O.	HMOTNOSŤ kg
ROZM.-POLOT							
POM. ZAR.					STN	TR.Č.	
VYPR.	Ing. Kluska M.				POZN.	Č.POZÍCIE	
PRESK.							
TECHNOL.		TECHNOL.			STARÝ V.	Č.V.	
NÁZOV	Zvodová objímka s hrotom 300 mm				Počet listov	P-PODD	List 

Vytvorené: 06.06.2026 10:31:37

Technické zmeny vyhradené

Rozmery [mm]		
Menovitá veľkosť	Ø A	L
100	100	300